

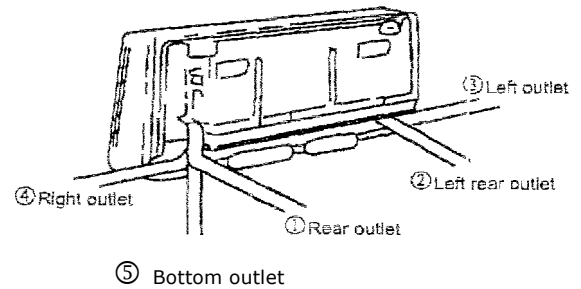

Installation

Installation of the indoor unit

Pipelines can be connected in the directions of ①, ②, ③, ④, and ⑤ as indicated in Figure 3. When the pipelines are connected to the directions of ③, ④, and ⑤, a groove for the pipes has to be opened at the proper place on the base stand.



1. Installation of wall-mounting plate.

Fix the wall-mounting plate firmly on the wall with screws. Make sure of the leveling of the plate. Slanted wall-mounting plate might jeopardize the smooth discharge of the condensed water.



2. Drill holes on the wall

Drill holes at places slightly below the wall-mounting plate with hole diameter of 65mm and the outer edge of the hole 5-10mm lower so that the condensed water can smoothly flow out. Cut the wall penetrating pipe to proper length according to the thickness of the wall (3-5mm longer than the wall thickness) and insert the pipe.

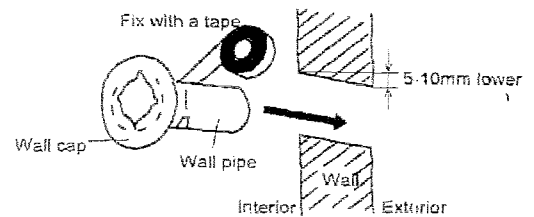

3. Installation of drain pipe

Install the pipelines of the indoor unit in accordance with the direction of the wall holes. Wrap tightly the drainpipe and the pipelines with tape. Make sure that the drainpipe is underneath the pipelines. (When the drainpipe passes the room interior, some condensed water might occur to its surfaces if the humidity is very high).

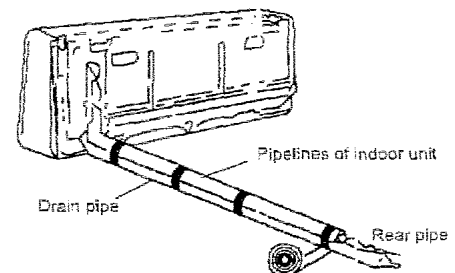



4. Installation of indoor unit

Pass the connection wires, connecting pipelines and drain pipe through the wall hole, Hang the indoor unit on the hooks at the top of the wall-mounting plate so that the hooks at the bottom of the indoor unit match the hooks of the wall-mounting plate.

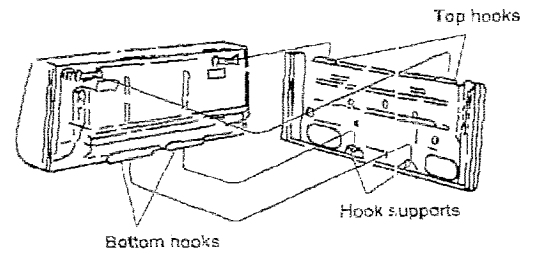

Inspections:

- See if the hooks at the top and bottom are firmly fixed.
- See if the position of the master unit is properly leveled
- The drainpipe should not curve upward.
- The drainpipe should be at the lower part of the wall pipes.



5. Wire connections of indoor and outdoor units

Connect the wires of the indoor and outdoor units properly according to the schematic diagram, The appliance shall be installed in accordance with national wiring regulation.

Note. Do not connect the wires in a wrong way, otherwise electric malfunctions will be caused and even damages to the units will occur.

The provision for connection of one of the wiring systems that in accordance with the National Electric Code shall be had. ANSI/NFPA 70-1990 would be acceptable for it.

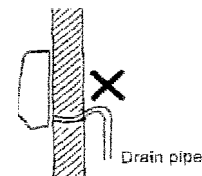
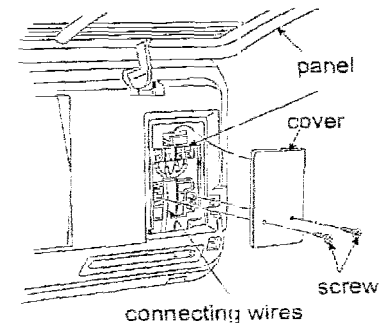



Selection of Installation options for the outdoor unit

- To install the outdoor unit at the places which can stand the load of the machine weight and will not cause big vibrations and noises;
- To install the unit at the places with good ventilation;
- Install the unit on metal frame or strong place.
- Not to install the unit at the daces where 'there might occur the generation, inflow, stay or leakage of inflammable gases:
- Pay attention to the drainage of the condensed water from the base plate during operations;
- To avoid the air outlet being directly against the wind.



Detailed space requirements around the outdoor unit

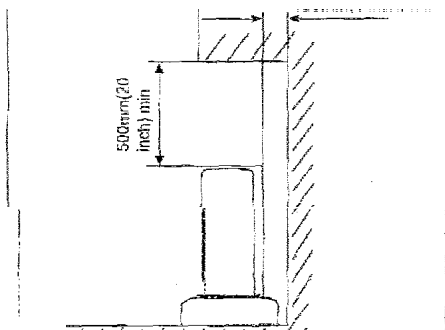

1. When there are obstacles above the unit.

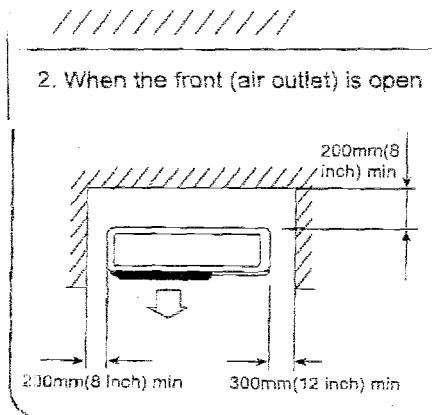

2. When the front (air outlet) is open

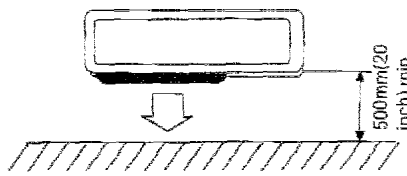

3. When there are obstacles only in the front (air outlet)

4. When there are obstacles at the front and rear sides, please do not use the following dimensions:

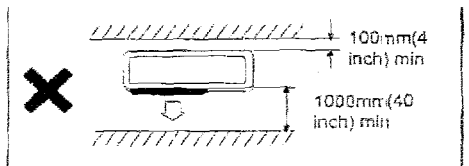

5. When there are obstacles all around the unit on four sides. Although the topside is open, the installation is not to be done if there are obstacles all around.

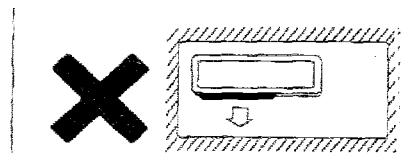

• At least two sides should be kept open.



Installation and fixing of the outdoor

1. Try to ship the product to the installation location in its original package;
2. As the gravity center of the units is not at the installation center, special caution should be taken when using hoisting cables to lift it up;
3. During shipping, the outdoor unit must not be slanted to over 45 degrees (Do not store the unit in a horizontal way),
4. Use expansion bolts to fix the mounting supports on the wall;
5. Use bolts and nuts to fix the outdoor unit firmly on the supports and keep on the same level;
6. If the unit is installed on the wall or at the rooftop, the supports have to be firmly fixed so as to resist earthquake or strong wind.



Installation of refrigerant pipe and drainage tube

- a. The connecting pipelines are not supplied
- b. In some special cases, it is needed to buy thermal insulation materials with a thickness of 12mm minimum and the thermal sheath with good property so as to prevent from dew-dropping.
- c. When the installation of the drainage tube passes the indoor space, thermal-keeping measures should be taken to prevent from dew-dropping.
- d. Our accessories for piping lines are recommended in general.

1. Dimensions of refrigerant pipe and drainage tube (outer diameter)

in the case that there is the need to purchase additional refrigerant pipe or drainage tube, please refer to the following table:

Item		Model	2500W (9,000 BTU) Series	3500W (12,000 BTU) Series
Refrigerant Pipe	Liquid pipe		Ø6.35 (1/4")	Ø6.35 (1/4")
	Gas pipe		Ø9.52 (3/8")	Ø12.7 (1/2")
Drainage Tube			PVC Tubes VP-20 [Outer diameter 26(1")]	

2. Installation of refrigerant pipes

Sequence of pipe preparation sequence



a. Keep the stop-valve or ball.-valve of the outdoor unit in the original closed state (ex- factory state). Remove the screw nuts, dust-resistance caps and pipe end screw blocks from the indoor and outdoor pipes;

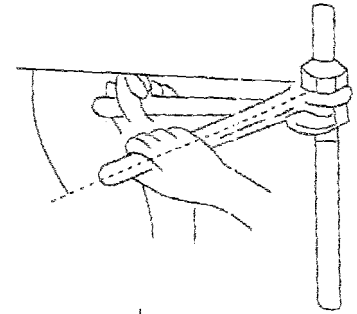

- Do the bell-mouth connections quickly, if the pipes are left uncared for long time, the dust, water or other objects will enter the pipes, which might cause troubles. (failure)
- Before tightening the bell-mouth nuts, a thin layer of anti-freezing grease should be placed on the surface of the connection between the pipe and the joint.
- When the connection of pipes is made, please use two wrenches, The related torque forces are shown in the following table:

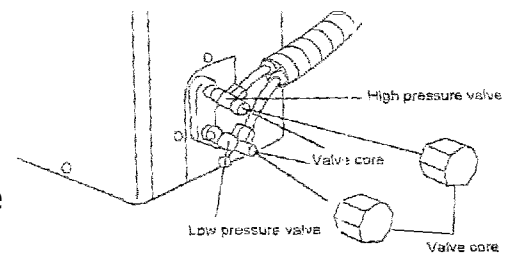

Torque forces based upon the wrench to be used,

Outer diameter of copper pipe	Torque Force	
Ø 6.35 (1/4")	145 - 175 (kg/cm)	368 - 444 (kg/cm)
Ø 9.52 (3/8")	350 - 420 (kg/cm)	888 - 1066 (kg/cm)
Ø 12.7 (1/2")	550 - 600 (kg/cm)	1369 - 1523 (kg/cm)
Ø 15.88 (5/8")	750 - 800 (kg/cm)	1904 - 2030 (kg/cm)
Ø 19.05 (3/4")	1000 - 1400 (kg/cm)	2538 - 3553 (kg/cm)

- b. Do the bell mouth connections one by one until all the refrigerant pipes are well connected. After the pipes are connected, you must do the leakage checks by soap water or a special detective device to see if there is leakage.
- c. Puma vacuum at the maintenance access opening of the outdoor unit strip valve or ball valve, or use the refrigerant inside unit to discharge the air in the pipes (to be operated by professional technicians only).
- d. After completing the above procedures, turn the step valve or the ball valve to fully open state.



3. Adjustment of refrigerant volume

The volume of refrigerant for KFR-25GW/BGb, is 700g, and KFR-35GW/BGb, is 1050g. When the pipe length is within 7.5 meters(295 inch), there is no need to add more refrigerant to the unit. When the length above 7.5 meters(295 inch), please add more refrigerant according to the allowances indicated in the following table:

Maximum Allowance for Length	Additional volume of refrigerant (kg)
≤ 10m (394 inch)	0.015 kg/m
≤ 15m (591 inch)	0.03 Kg/m

⌘ When additional refrigerant is filled in, please use the needle valve on the low-pressure valve of the outdoor unit.

4. Installation of drainage tubes

a. The drainage tubes must be slanted downward' to ensure that water is not accumulated;

b. There might be condensing water on the surface of the drainage tubes. Please purchase thermal insulation sheath as needed;

c. The joints must be firmly adhered together by applying polyvinyl adhesives to prevent from leakage;

d. Do not directly insert the drainage tube into the sewer tunnel which might generate sulfate gases or into the places which might generate unpleasant smell.

5. Considerations on the drainage of the outdoor unit

During heating operation, the holes on the base of the outdoor unit might drop out some condensing water. You have to take this into consideration when doing the installation so as to avoid the impacts on the environment by the water drops.

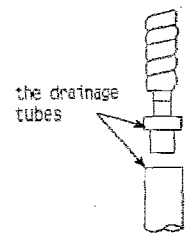

Installation of Electric Components

Points of attention:

a. HACR type breaker should be utilized along with proper installation

b. Make sure of the applicable voltage and cables or wires for the specific model to be used, before doing the connections;

c. Read the prompts at the terminal board for wiring. Make sure the wiring is done correctly.

d. Pay attention to the poles of the signal terminal and connect the terminals to match the identification numbers.

e. When the wiring connections are wrong, the compressor will not work.

f. The connecting wires are not supplied,



g. The connecting wires specification 14 AWG,VW-1(orTHHW),copper core and 164°F for model 2500W and model 3500W. Their set screw diameter is 4 mm.The power sours is 115V, 60Hz and 1 Phase. Minimum circuit ampacity of the wiring systems is 20A.

Connection of wires for outdoor unit

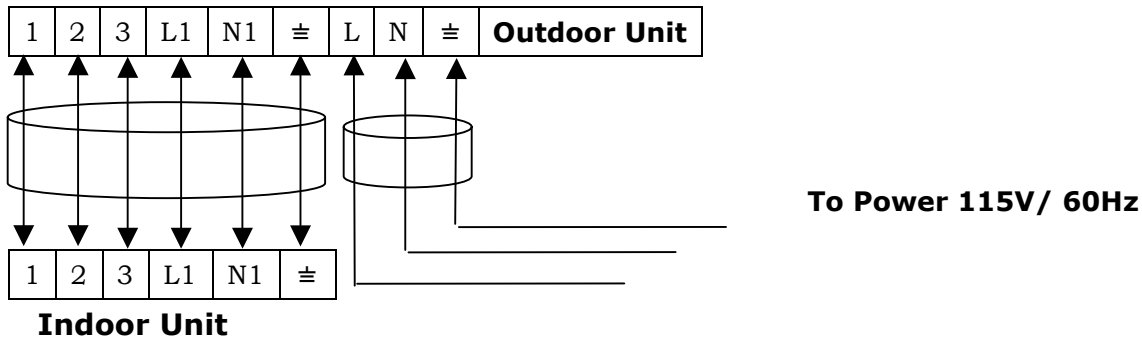

Note:

- The environment conditions must be taken into consideration when the connections of power cable are made (such as the ambient temperature, direct exposure to heat/ direct exposure to sunlight);
- The specifications for the power cable refer to the minimum values of the metal core wires Taking into consideration the voltage losses, the core wire of power cable must be one size larger than the specifications;
- The grounding wire must be connected to the indoor units and outdoor units;
- The laying of power cables must be done by qualified electricians and comply with the regulations of the local power supply authorities and with the standards of the electric appliances;

Test Running:

- Connect to the power source, check if the function selection keys or, the remote controller are working properly.
- Check if the room temperature adjustments and timer settings are working properly.
- Check if the drain is smooth.
- Check if there is any abnormal noise or vibration during operation,
- Check if there is leakage of refrigerant.

Is the unit installed correctly?



1. Suitable Installation Position.

Isn't there anything which prevents ventilation or obstructs operation in front of the indoor unit? Do not install the unit at following places.

- a. Inflammable gases may leak.
- b. Oil splashes a lot.
- c. In case where the unit is used in such places as poisonous or sultry gases are generated or seaside district exposed to sea breezes corrosion may cause malfunction. Consult with your distributor.
- d. Air conditioner body and remote controller must be out or more away from a TV or a radio.
- e. Drain the dehumidified water from the indoor unit to a place, which drains well.

2. Pay attention to operation noise

- a. When installing the unit choose a place, which can stand the weight of the unit well and does not increase the operation noise or vibration. Especially where there is a possibility that vibration be transmitted to the house, fix the unit by- inserting attached vibration -proof pads between the unit and fittings.
- b. Choose the place where hot air and operation noise from the outlet of the outdoor unit do not annoy the neighborhood.
- c. Things left near the outlet and inlet of the outdoor unit cause malfunction or increased operation noise. Do not leave obstacles near the outlet and inlet.
- d. If irregular sound is heard during operation, consult with your distributor.

3. Inspection and Maintenance

According to the service conditions and operating environment; the inside of the air conditioner will become dirty after several seasons (3 to 5 years) of service, resulting in decreased operating performance. Inspection and maintenance are recommended in addition to usual cleaning (The air conditioner can be used for a longer period and without anxiety.)

As to inspection and maintenance, consult your dealer or any one of service business offices of dealing companies. (Service charge is required in this case.)

We recommend performing inspection and maintenance during an off season.