

Selection of installation for indoor unit

- To be installed at the position where the air delivered from the unit can reach every corner of the room;
- To avoid being affected by the outdoor air;
- To avoid blockage to the air inlet or outlet of the unit;
- To avoid too much oil smoke or steam;
- To avoid possible generation, inflow, lingering or leakage of flammable gases;
- To avoid high-frequency facilities (such as high frequency arc welders, etc.);
- Not to install a fire alarming device near the air outlet of the unit (during operation, the fire alarm device might be erroneously triggered by the warm air from the unit);
- To avoid the places where acid solutions are frequently used;
- To avoid the places where some special sprayers (sulfides) are frequently used.

1. To install the unit on the rigid wall.

2. Make sure of enough space for installation and maintenance.

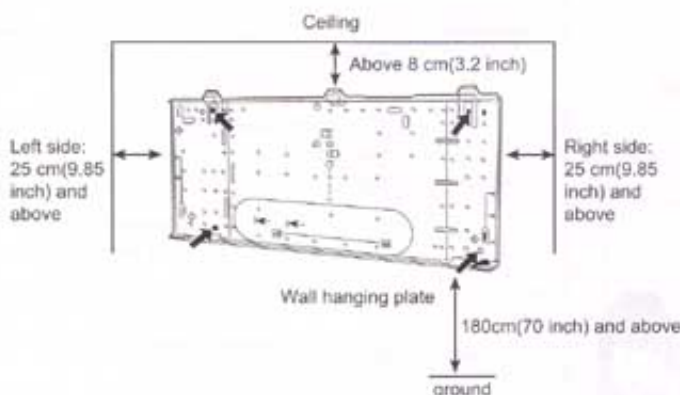

- To take into consideration the operational convenience and safety in installation, it is recommended to ensure enough space between the unit and the walls.
- As the wiring and maintenance is done at the front side of the unit, make sure of the above-shown minimum spaces for the sake of operational convenience and safety in installation.

3. High differences of the indoor and outdoor units, length limits to the refrigerant piping lines

Model	A. Length of Piping Line (one-way)		B. Height Differences
	max.	standard	
2500W(9000BTU) series	15m(591 inch) max.	7.5m(295 inch) standard	5m(197 inch) max.
3500W(12000BTU) series	15m(591 inch) max.	7.5m(295 inch) standard	5m(197 inch) max.

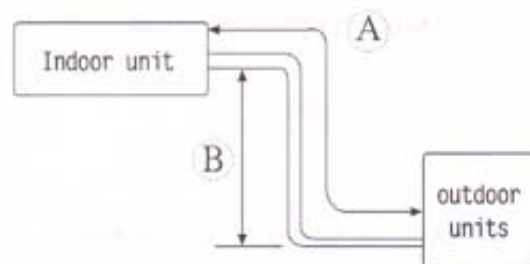

- Either the indoor unit or the outdoor unit can be higher, but the height difference must comply the above-stated requirements.
- Try to reduce the bending of the piping line as much as possible so as to avoid possible negative impacts upon the performances of the units.

Installation

Installation of the indoor unit

Installation of the indoor units

Pipe lines can be connected in the directions of ①、②、③、④、 and ⑤ as indicated in Figure 3. When the pipelines are connected to the directions of ③、④ and ⑤, a groove for the pipes has to be opened at the proper place on the base stand.

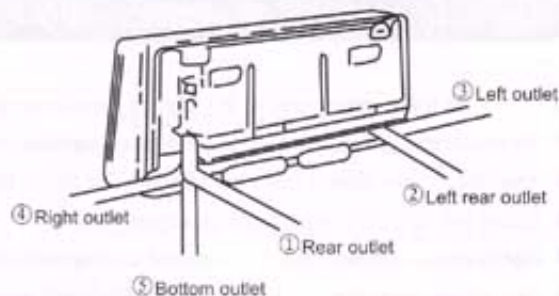

1. Installation of wall-mounting plate

Fix the wall-mounting plate firmly on the wall with screws. Make sure of the leveling of the plate. Slanted wall-mounting plate might jeopardize the smooth discharge of the condensed water.

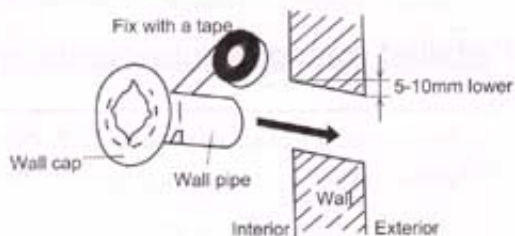

2. Drill holes on the wall

Drill holes at places slightly below the wall-mounting plate, with hole diameter of 65mm and the outer edge of the hole 5-10mm lower so that the condensed water can smoothly flow out. Cut the wall penetrating pipe to proper length according to the thickness of the wall (3-5mm longer than the wall thickness) and insert the pipe.

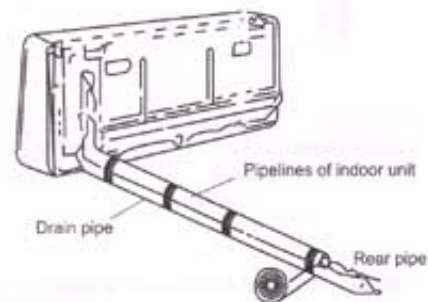

3. Installation of drain pipe

Install the pipelines of the indoor unit in accordance with the direction of the wall holes. Wrap tightly the drain pipe and the pipelines with tape. Make sure that the drain pipe is underneath the pipelines. (When the drain pipe passes the room interior, some condensed water might occur to its surfaces if the humidity is very high).

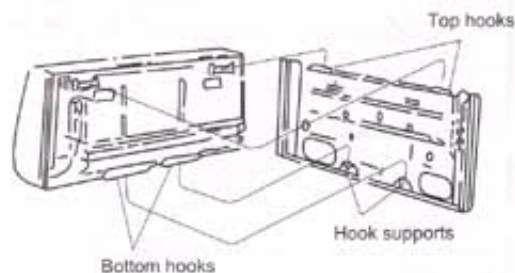

4. Installation of indoor unit

Pass the connection wires, connecting pipelines and drain pipe through the wall hole. Hang the indoor unit on the hooks at the top of the wall-mounting plate so that the hooks at the bottom of the indoor unit match the hooks of the wall-mounting plate.

Inspections:

- See if the hooks at the top and bottom are firmly fixed.
- See if the position of the master unit is properly leveled.
- The drain pipe should not curve upward.
- The drain pipe should be at the lower part of the wall pipes.

5. Wire connections of indoor and outdoor units

Connect the wires of the indoor and outdoor units properly according to the schematic diagram. The appliance shall be installed in accordance with national wiring regulation.

Note: Do not connect the wires in a wrong way, otherwise electric malfunctions will be caused and even damages to the units will occur.

The provision for connection of one of the wiring systems that in accordance with the National Electric Code shall be had. ANSI/NFPA 70-1990 would be acceptable for it.

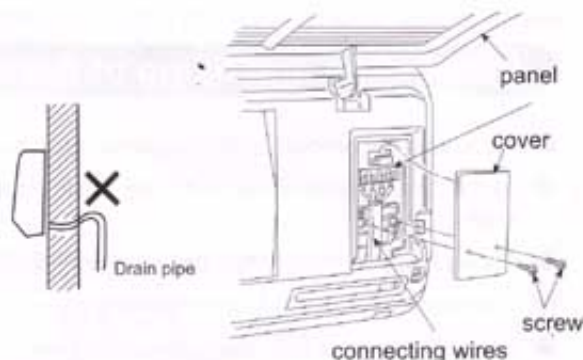



Installation

Selection of installation options for the outdoor unit

- To install the outdoor unit at the places which can stand the load of the machine weight and will not cause big vibrations and noises;
- To install the unit at the places with good ventilation;
- The noises generated from the unit will not affect the neighboring places;
- Install the unit on metal frame or strong place..
- Not to install the unit at the places where there might occur the generation, inflow, stay or leakage of inflammable gases;
- Pay attention to the drainage of the condensed water from the base plate during operations;
- To avoid the air outlet being directly against the wind.

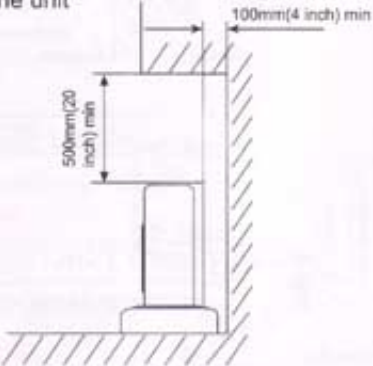
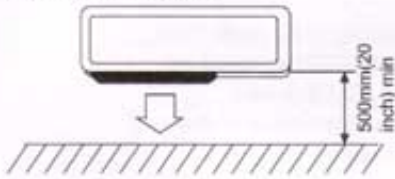
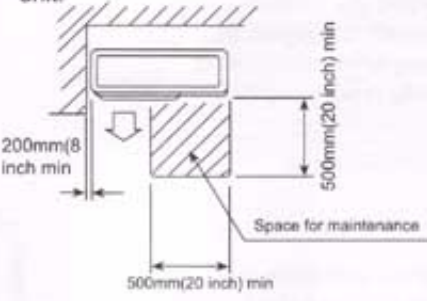
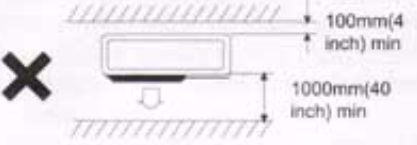
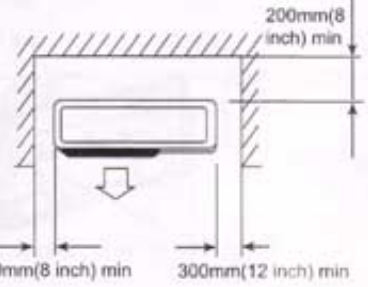
Detailed space requirements around the outdoor unit

<p>1. When there are obstacles above the unit</p> 	<p>3. When there are obstacles only in the front (air outlet)</p>  <p>Space for maintenance Shown as in the following figure. Keep the maintenance space in front of the unit.</p> 	<p>4. When there are obstacles at the front and rear sides, please do not use the following dimensions:</p> 
<p>2. When the front (air outlet) is open</p> 	<p>5. When there are obstacles all around the unit on four sides. Although the top side is open, the installation is not to be done if there are obstacles all around.</p>  <ul style="list-style-type: none">● At least two sides should be kept open.	

Installation and fixing of the outdoor

- Try to ship the product to the installation location in its original package;
- As the gravity center of the unit is not at the installation center, special caution should be taken when using hoisting cables to lift it up;
- During shipping, the outdoor unit must not be slanted to over 45 degrees (Do not store the unit in a horizontal way).
- Use expansion bolts to fix the mounting supports on the wall;
- Use bolts and nuts to fix the outdoor unit firmly on the supports and keep on the same level;
- If the unit is installed on the wall or at the rooftop, the supports have to be firmly fixed so as to resist earthquake or strong wind.

Installation

4. Installation of drainage tubes

- The drainage tubes must be slanted downwards to ensure that water is not accumulated;
- There might be condensing water on the surface of the drainage tubes. Please purchase thermal insulation sheath as needed;
- The joints must be firmly adhered together by applying polyvinyl adhesives to prevent from leakage;
- Do not directly insert the drainage tube into the sewer tunnel which might generate sulfate gases or into the places which might generate unpleasant smell.

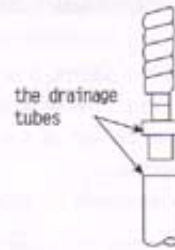

5. Considerations on the drainage of the outdoor unit

During heating operation, the holes on the base of the outdoor unit might drop out some condensing water. You have to take this into consideration when doing the installation so as to avoid the impacts on the environment by the water drops.

INSTALLATION OF ELECTRIC COMPONENTS

Points of attention

- HACR type breaker should be utilized along with proper installation;
- Make sure of the applicable voltage and cables or wires for the specific model to be used, before doing the connections;
- Read the prompts at the terminal board for wiring. Make sure the wiring is done correctly.
- Pay attention to the poles of the signal terminal and connect the terminals to match the identification numbers.
- When the wiring connections are wrong, the compressor will not work.
- The connecting wires are not supplied.
- The connecting wires specification 14 AWG,VW-1(orTHHW),copper core and 164°F for model 2500W and model 3500W Their set screw diameter is 4 mm.The power source is 115V,60Hz and 1phase.Minimum circuit ampacity of the wiring systems is 20A.

Connection of wires for outdoor unit

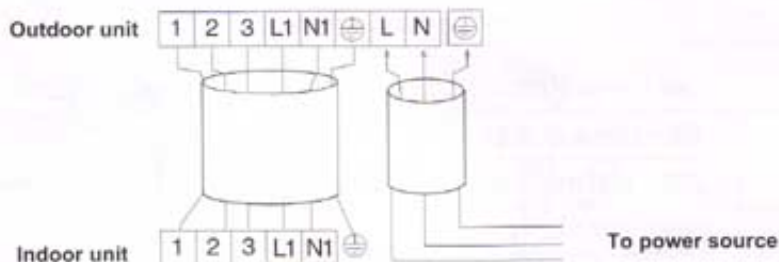

Note:

- The environment conditions must be taken into consideration when the connections of power cable are made (such as the ambient temperature, direct exposure to heat/direct exposure to sunlight);
- The specifications for the power cable refer to the minimum values of the metal core wires. Taking into consideration the voltage losses, the core wire of power cable must be one size larger than the specifications;
- The grounding wire must be connected to the indoor units and outdoor units;
- The laying of power cables must be done by qualified electricians and comply with the regulations of the local power supply authorities and with the standards of the electric appliances;

Test running

- Connect to the power source, check if the function selection keys on the remote controller are working properly.
- Check if the room temperature adjustments and timer settings are working properly.
- Check if the drain is smooth.
- Check if there is any abnormal noise or vibration during operation.
- Check if there is leakage of refrigerant.